

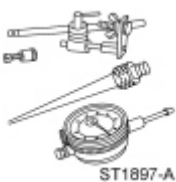
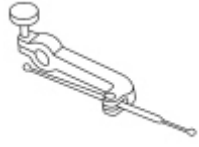

Transmission

Special Tool(s)

 <p>ST1897-A</p>	<p>Dial Indicator Gauge with Holding Fixture 100-002 (TOOL-4201-C) or equivalent</p>
 <p>ST1348-A</p>	<p>Gauge, Clutch Housing 308-021 (T75L-4201-A)</p>
 <p>ST2360-A</p>	<p>Installer, Torrington Bearing 308-083 (T83P-7025-AH)</p>
 <p>ST2199-A</p>	<p>Installer, Transmission Extension Housing Oil Seal 308-227 (T94P-7657-A)</p>
 <p>ST2147-A</p>	<p>Remover/Installer, Bearing Tube 308-052 (T77J-7025-B)</p>

Material

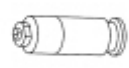
Item	Specification
Clear Silicone Rubber TA-32	ESB-M4G92-A
MERCON® V Automatic Transmission Fluid XT-5-QM (or XT-5-QMC) (US); CXT-5-LM12 (Canada)	MERCON® V
Multi-Purpose Grease XG-4 and/or XL-5	ESB-M1C93-B
Premium Long-Life Grease XG-1-C or XG-1-K (US); CXG-1-C (Canada)	ESA-M1C75-B
Thread Sealant with PTFE TA-24	WSK-M2G350-A2

Transmission Case and Shift Components — Disassembled View

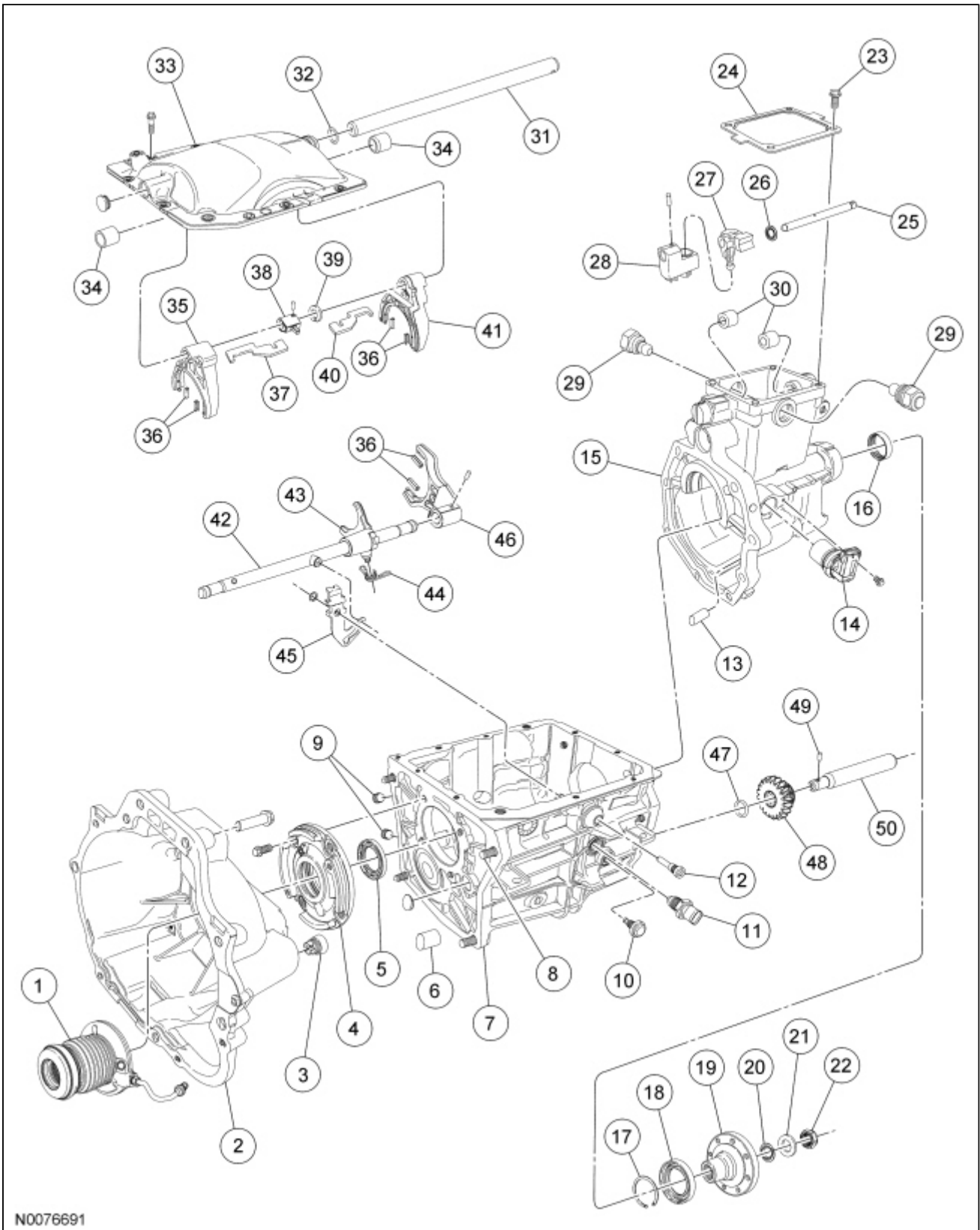

N0076691

Item	Part Number	Description
1	7A508	Slave cylinder and release bearing
2	7500	Clutch housing
3	7K584	Slave cylinder line retainer
4	7050	Input shaft bearing retainer
5	7052	Input shaft seal

6	7W425	Shaft bearing
7	7005	Main case
8	7A443	Main case-to-clutch housing bolt
9	87675-S	Drain and fill plugs
10	7K024	Reverse lever pivot bolt
11	15520	Reverse lamp switch
12	7K024	Shift lever reverse pin
13	7W425	Shaft bearing
14	7H103	Output Shaft Speed (OSS) sensor
15	7A039	Extension housing
16	7065	Extension housing bearing
17	7109	Extension housing bearing snap ring
18	7052	Output shaft seal
19	7K359	Transmission flange
20	7E397	Flange seal
21	7119	Thrust washer
22	7K440	Output flange nut
23	7A443	Gear shift cover bolt
24	7222	Gear shift cover
25	7240	Shift rail selector
26	7052	Selector rail seal
27	7N094	Selector finger
28	7F018	Gearshift offset lever
29	7234	Shifter detents
30	7127	Main shift rail bearings
31	7358	Main shift control shaft
32	87038-S91	Main shift rail seal
33	7222	Transmission case cover
34	7W425	Main shift control shaft bushings
35	7230	3rd/4th gear shift fork
36	7L082	Shift fork inserts
37	7N232	Gear shift plate
38	7302	Selector body
39	7K201	Gear selector interlock sleeve
40	7N232	Gear shift plate
41	7230	1st/2nd gear shift fork
42	7240	Reverse gear shift rail
43	7230	Reverse shift fork
44	7E485	Reverse shift fork spring
45	7K002	Reverse gearshift lever
46	7230	5th gear shift fork
47	7E397	Reverse gear overtravel stop
48	7141	Reverse idler gear and bushing
49	357479-S15	Pin

1. **NOTE:** Soak the blocking rings in transmission fluid.

Lubricate all components with transmission fluid during assembly.

2. If removed, install new rail bearings into the transmission case.
3. If removed, install new main shift rail bearings into the extension housing.
4. Position the countershaft cluster gear in the case.

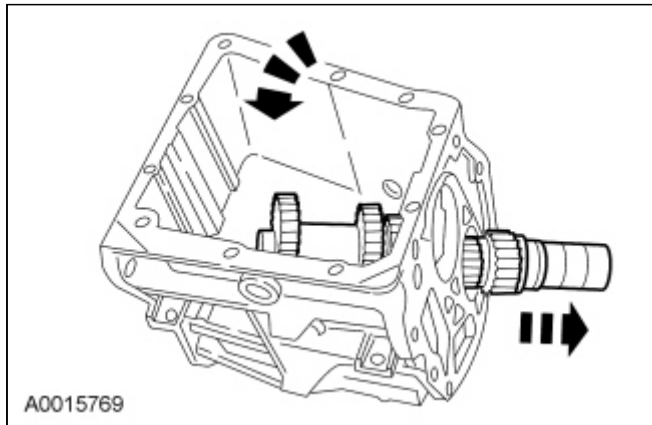

5. **NOTICE:** Failure to correctly support the case during bearing installation will result in permanent distortion of the case.

Using the Bearing Tube Remover/Installer and Torrington Bearing Installer and a press, install the rear countershaft bearing assembly.

1. Position two 6.35 mm (0.25 in) pieces of bar stock between the countershaft and the case.
2. Press the rear countershaft bearing assembly in the case.

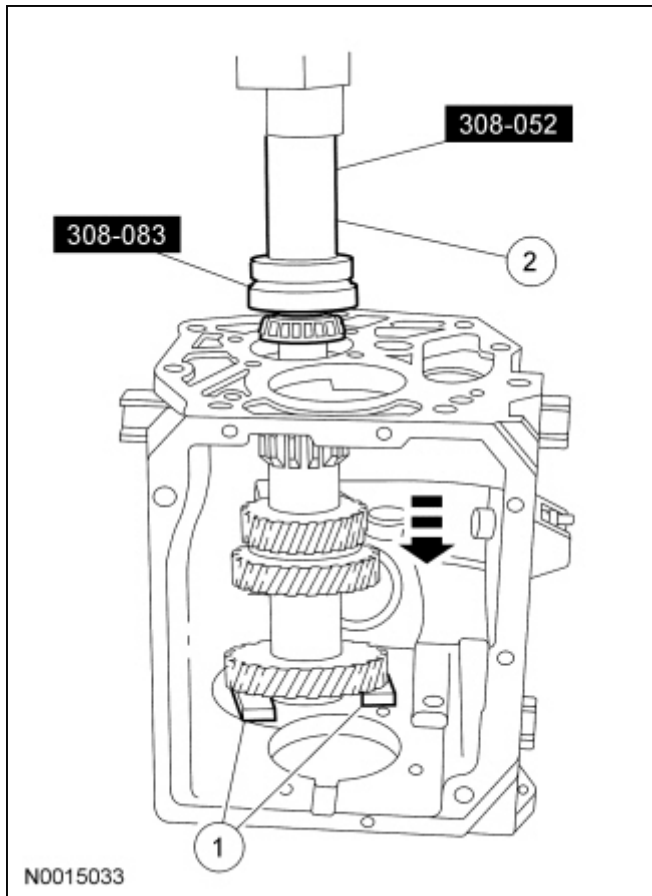

6. Position the reverse idler gear and bushing in the case with the shift lever groove facing the rear of the case. Install the reverse idler gear shaft and the reverse gear overtravel stop.

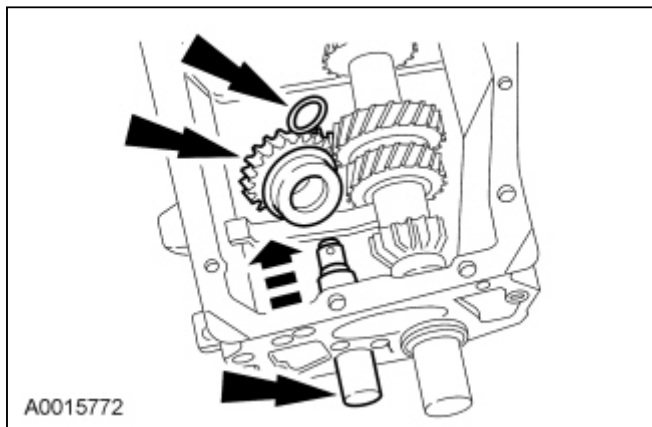

7. Install the rear countershaft bearing cup.

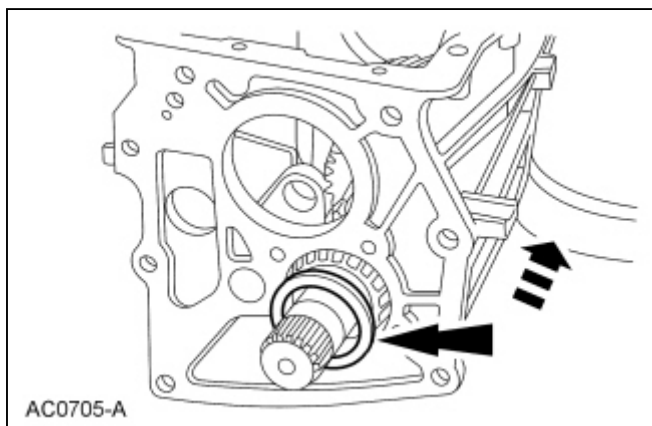

8. **NOTE:** Do not install the shims at this time.

Install the countershaft rear bearing retainer.

- Tighten to 21 Nm (15 lb-ft).

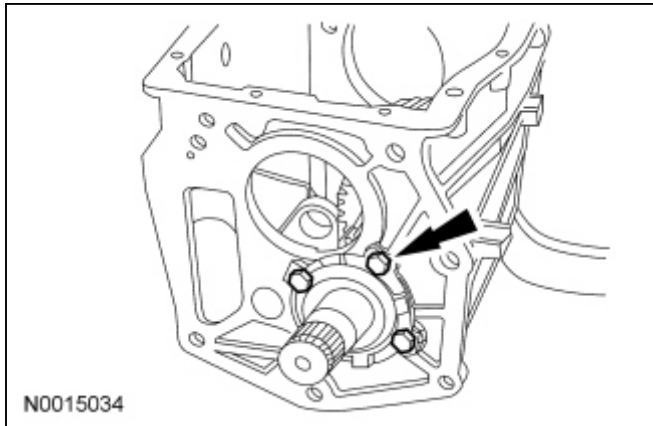

9. Using the Dial Indicator Gauge with Holding Fixture and Clutch Housing Gauge, measure the countershaft cluster gear end play.

- If the end play is not within specification, remove the countershaft rear bearing retainer and install the necessary thickness shim(s). Reinstall the countershaft rear bearing retainer and recheck the end play.
- Bend the tabs of the countershaft rear bearing retainer over the bolts when the end play adjustment is complete.

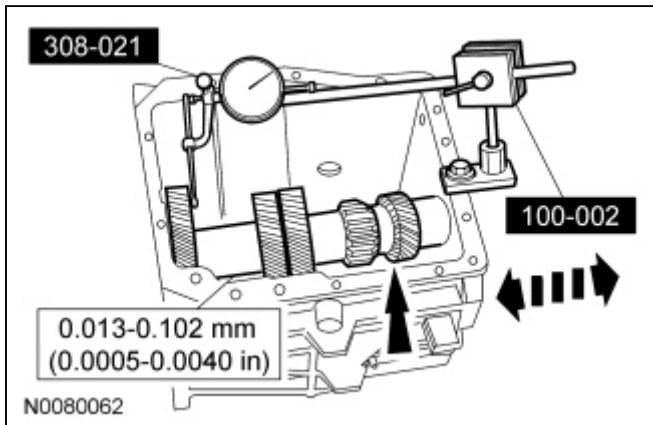

10. Install a new roll pin.

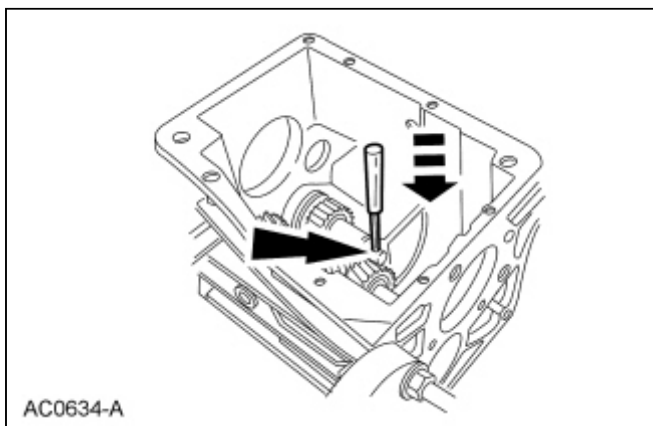

11. Align the reverse gearshift lever, the reverse shift fork and the reverse positioning spring.

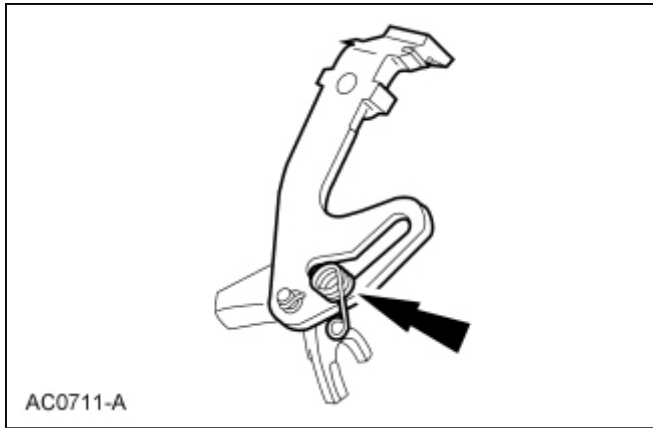

12. **NOTE:** Observe the reverse positioning spring rotation. The spring must rotate counterclockwise into its installed position.

Install the reverse shift fork.

- Place the reverse idler gear and bushing into the NEUTRAL position. Align the reverse shift fork and the reverse idler gear and bushing. Push downward on the reverse shift fork until fully engaged into the reverse idler gear and bushing.

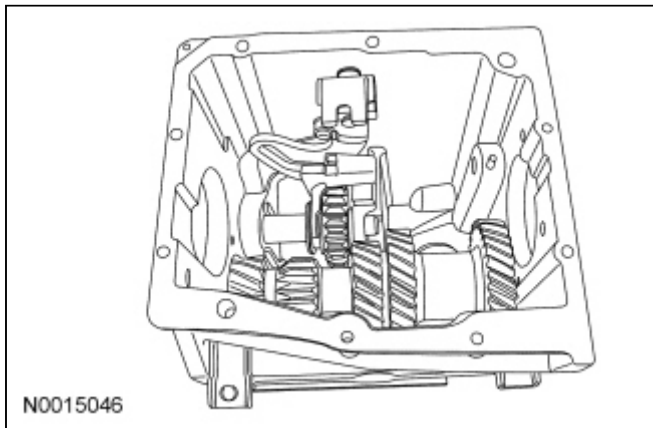

13. Install the output shaft assembly.

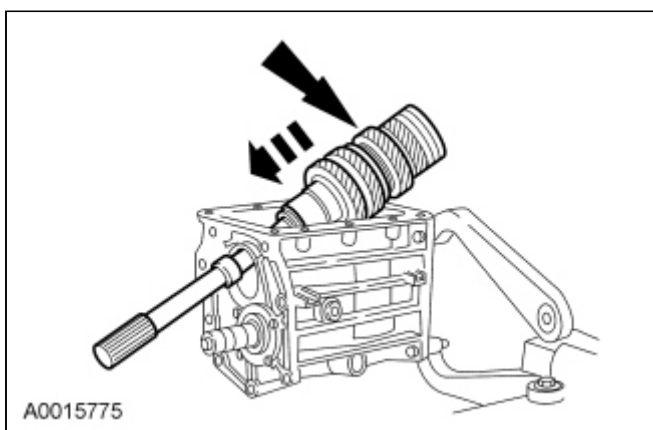

14. Apply pipe sealant to the shift lever reverse pin threads. Position the looped end of the reverse positioning spring around the shift lever reverse pin. Install the pin.

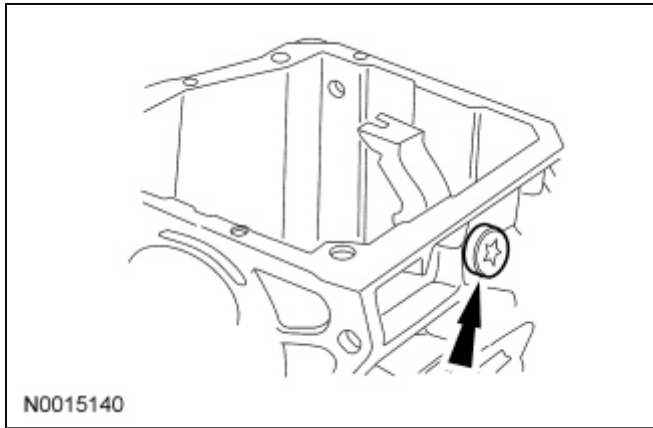

15. **NOTE:** Coat the 15 bearings, the spacer, the thrust bearing and the thrust washer with grease.
Install the roller bearings, the input shaft bearing spacer, the thrust bearing and the thrust washer.

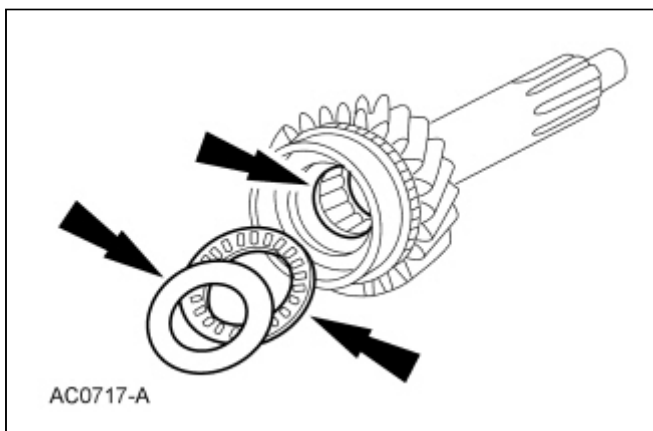

16. Align the notches in the synchronizer blocking ring and the synchronizer hub inserts. Install the 4th gear synchronizer blocking ring.

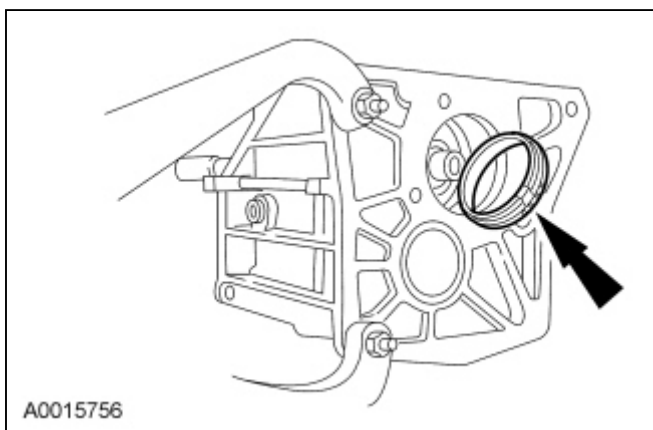

17. **NOTE:** Verify that the 4th speed synchronizer blocking ring is still in position.
Align the flat on the 4th gear clutching teeth with the countershaft cluster gear, then install the input shaft.

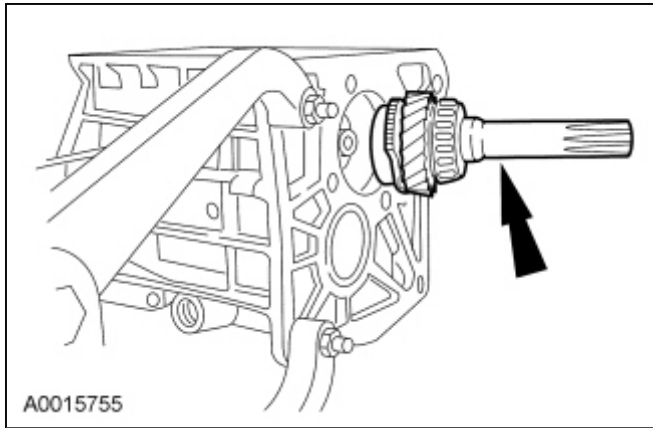

18. **NOTE:** Do not install the end play shims at this time.

NOTE: Do not apply sealant to the input shaft bearing retainer at this time.

Install the bearing race in the bearing retainer.

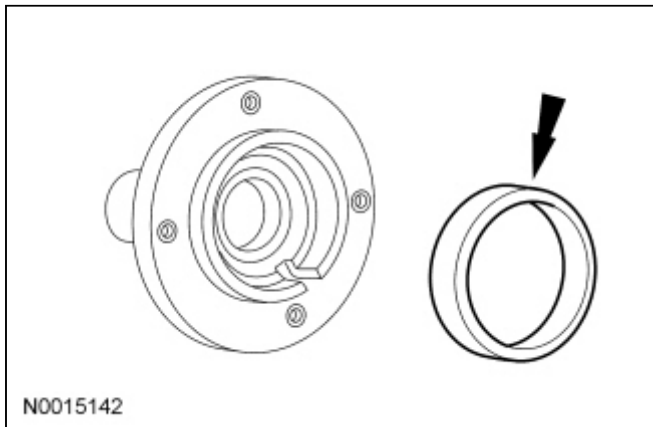

19. Install the input shaft bearing retainer with the notch facing upward.

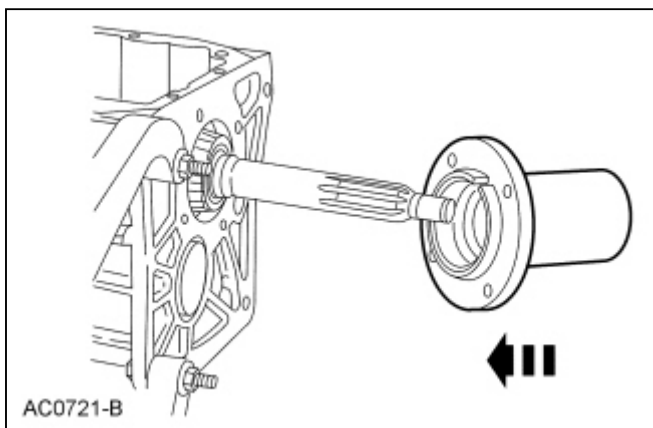

20. Install the 4 input shaft bearing retainer bolts.

- Tighten to 21 Nm (15 lb-ft).

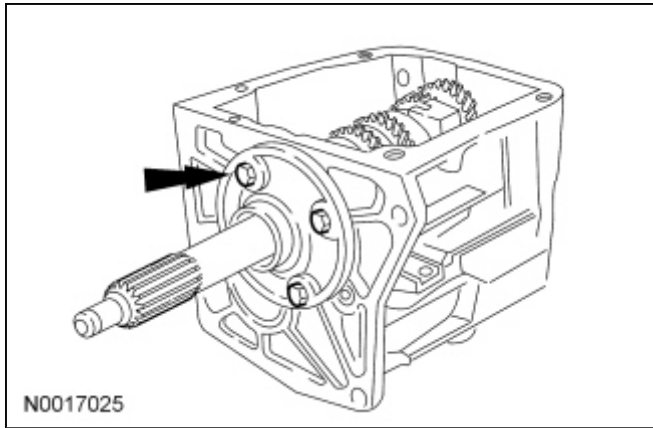

21. Install 5th gear and the output shaft rear bearing cup.

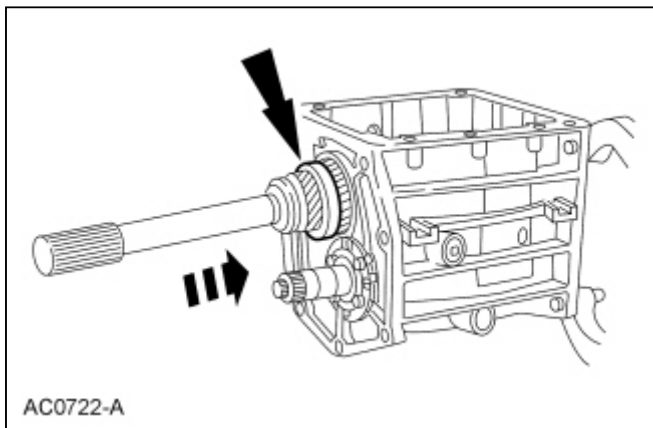

22. Install the reverse gear shift rail. Align the ball stud with the slot in the case and align the reverse gear shift rail with the reverse shift fork. Once the ball stud enters the case, rotate the reverse gear shift rail until the ball aligns with the reverse gearshift lever. Rotate the reverse gear shift rail counterclockwise until the ball stud fully engages the reverse gearshift lever.

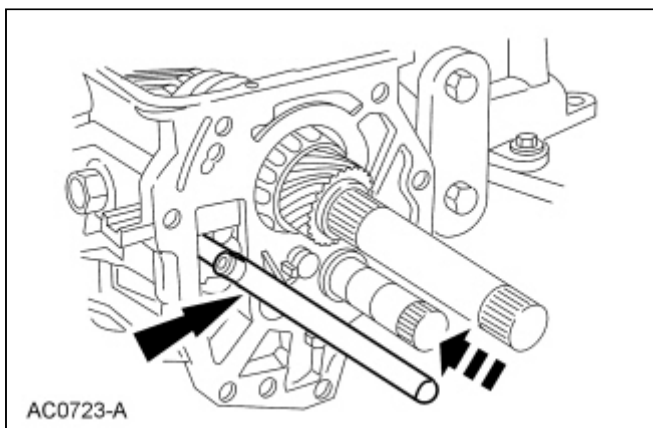

23. Install the 5th gear shifter fork, the synchronizer blocking ring, the synchronizer assembly and the 5th gear shifter fork pin as an assembly.

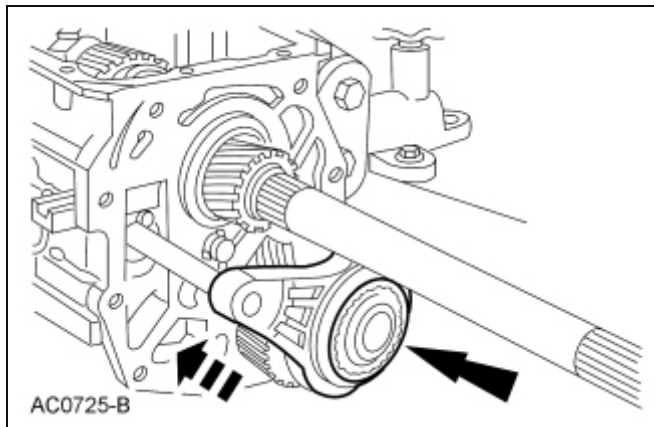

24. **NOTICE:** To prevent component damage when installing the extension housing, the alignment tab on the reverse brake ring must engage the alignment slot in the extension housing.

Install the synchronizer blocking ring, the reverse brake ring, the thrust washer and a new 5th speed synchronizer retaining snap ring.

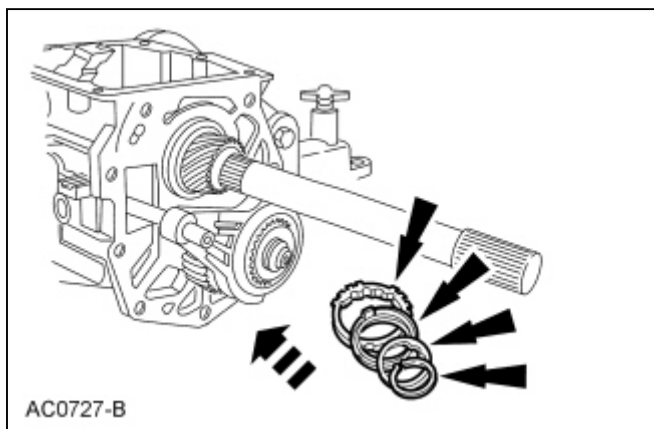

25. Apply pipe sealant to the reversing lamp switch threads and install the switch.
- Tighten to 37 Nm (27 lb-ft).

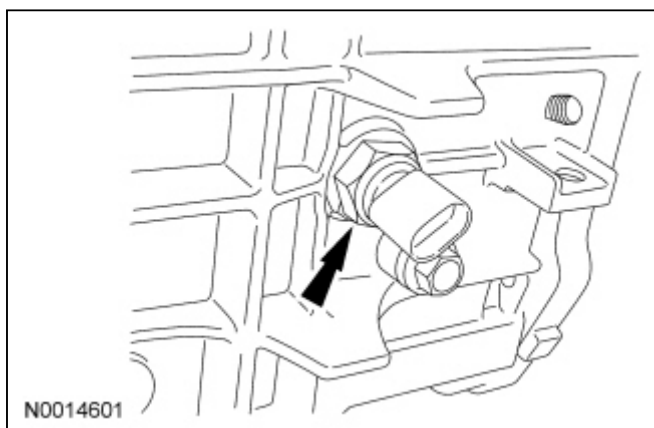

26. Install the reverse gearshift lever retaining clip.

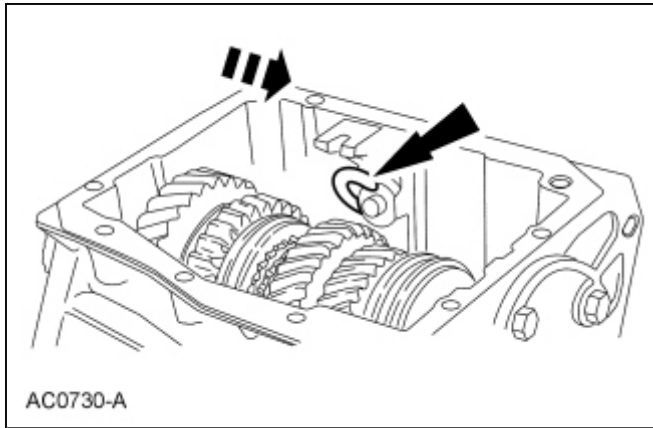

27. **NOTICE:** Do not, under any circumstance, apply silicone sealant to the top of the transmission case. The sealant could fall into the transmission and affect transmission operation.

Apply a 3.2 mm (0.125 in) bead of silicone rubber to the sealing surface on the case cover.

28. **NOTE:** Verify that all of the synchronizers are in the NEUTRAL position and the gear shifter forks in the cover are in the NEUTRAL position.

Position the case cover toward the filler plug side of the transmission and lower it until the gear shifter forks engage the synchronizers. Continue to lower the cover and move it into position to engage the reverse gearshift lever.

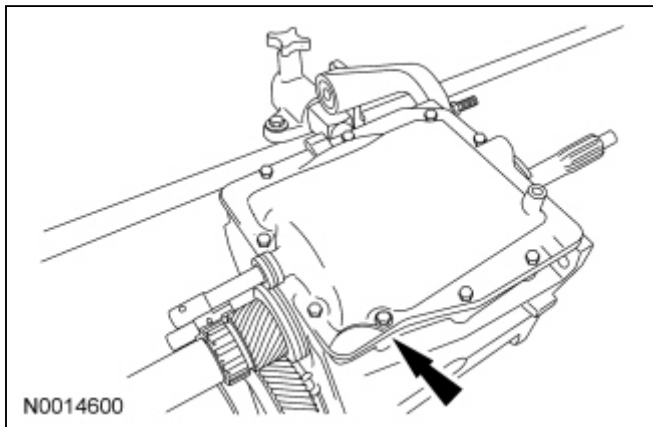

29. Install the 10 transmission case cover bolts.
 • Tighten to 12 Nm (106 lb-in).
30. Install a new output shaft bearing and a new snap ring.

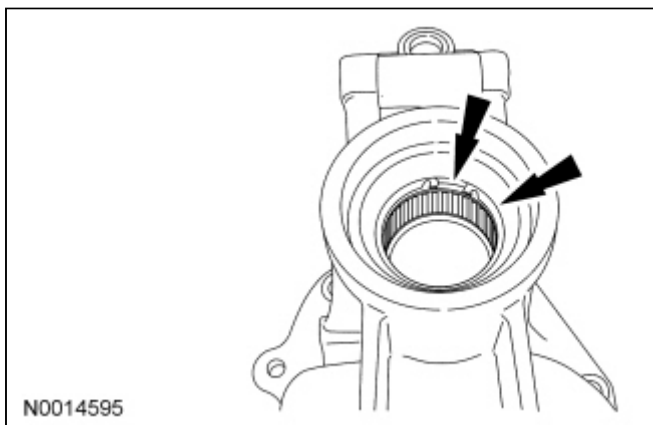

31. Using the Transmission Extension Housing Oil Seal Installer, install a new output shaft seal.

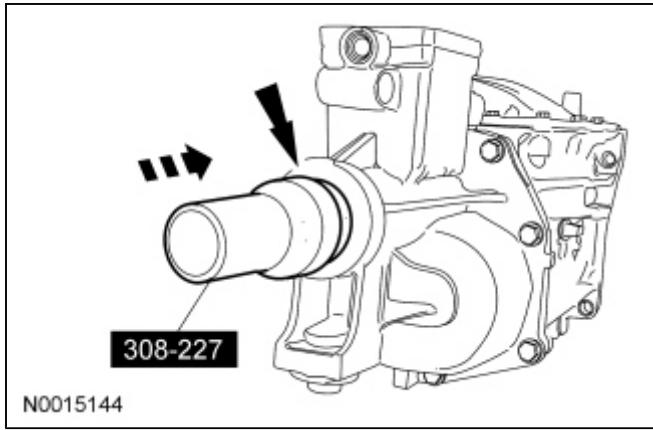

32. Install the large output shaft spacer.

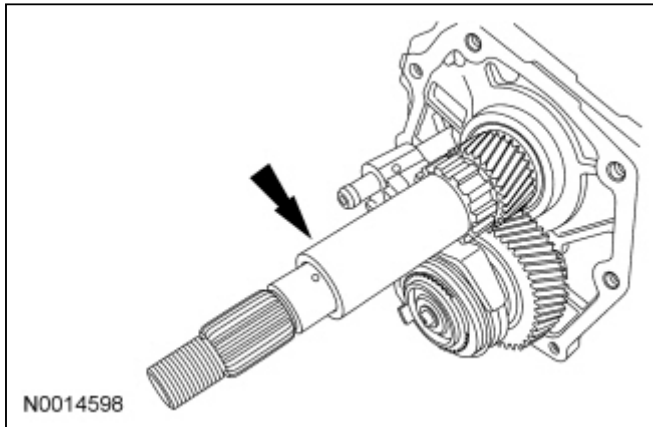

33. Install a new check ball.

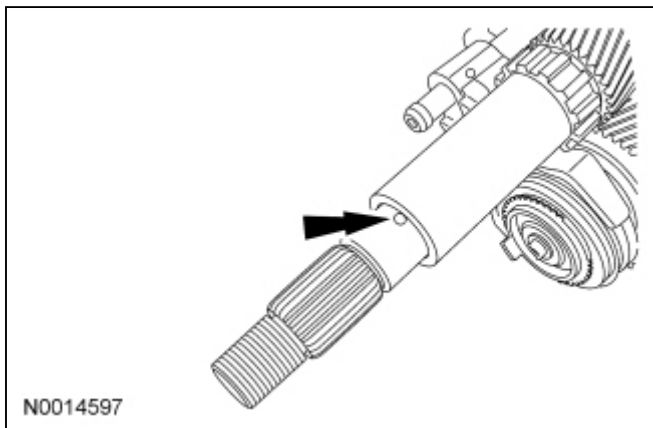

34. Install the small output shaft spacer.

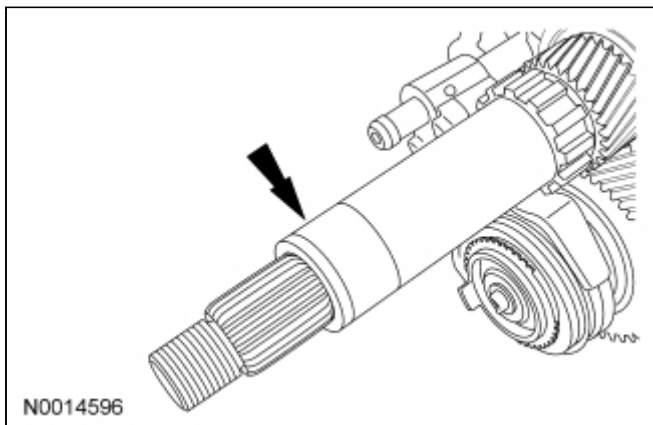

35. Apply a 3.2 mm (0.125 in) bead of silicone rubber to the sealing surface on the extension housing.

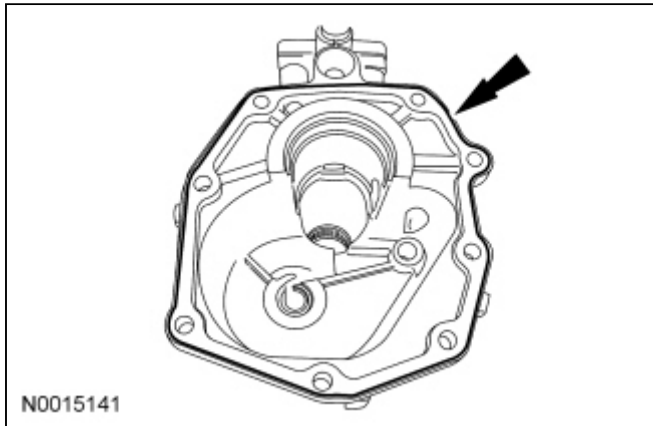

36. Lubricate the detent plate with multi-purpose grease. Position the gearshift offset lever in the extension housing.
37. **NOTICE:** To prevent component damage, the alignment tab on the reverse brake ring must align with the alignment slot in the extension housing.

NOTE: Verify that the oil pick-up funnel engages the 5th gear synchronizer.

Slide the gearshift offset lever onto the shift shaft and position the extension housing into place.

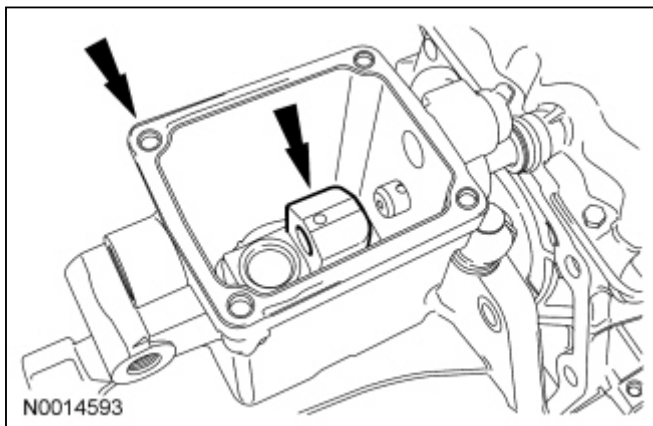

38. Install the identification tag and the 8 extension housing bolts.
- Tighten to 54 Nm (40 lb-ft).

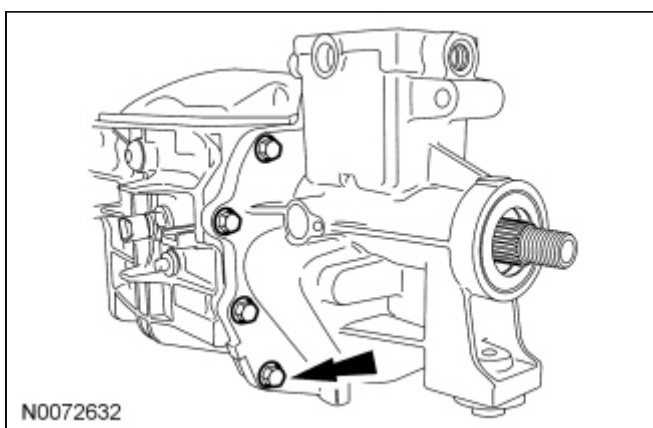

39. Install a new gearshift offset lever roll pin.

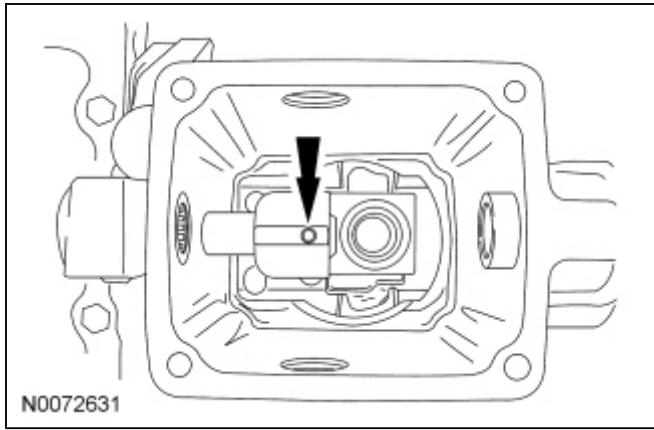

40. Install the shift lever and the gearshift shaft.

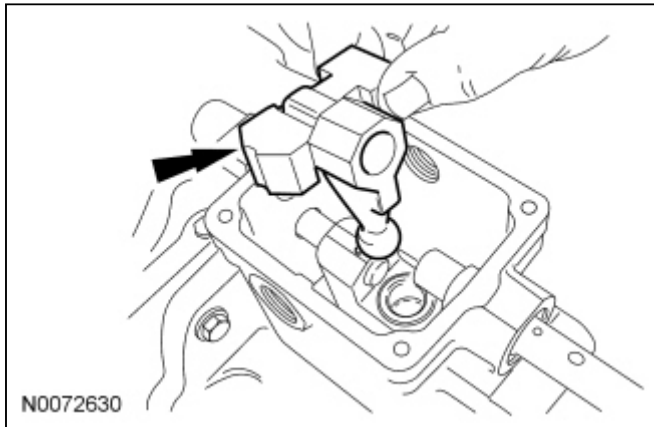

41. Install the shift lever detents.
• Tighten to 40 Nm (30 lb-ft).

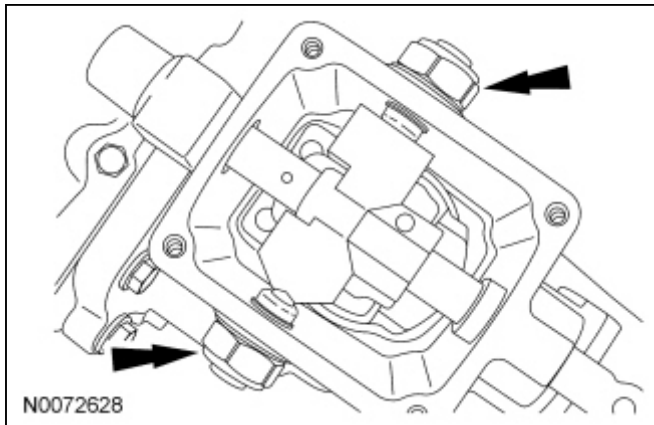

42. Install a new gearshift lever roll pin.

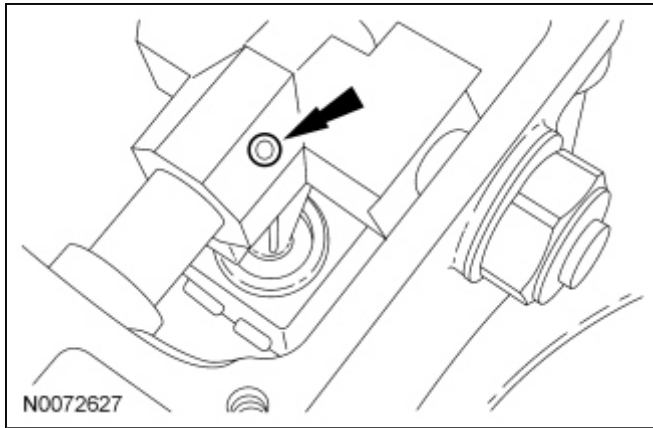

43. Using the Dial Indicator Gauge with Holding Fixture, measure the output shaft end play.
 1. Place the transmission in a vertical position.
 2. Install the Dial Indicator Gauge with Holding Fixture.
 3. Push upward on the input shaft and record the Dial Indicator Gauge reading.

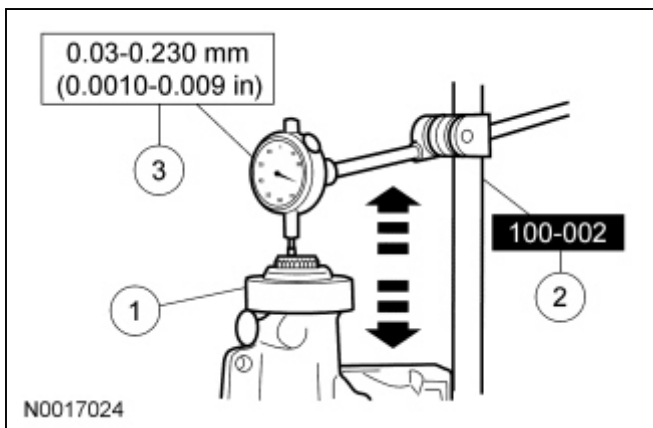

44. **NOTICE:** Although zero end play is the ideal, end play up to 0.230 mm (0.009 in) is an acceptable tolerance. Do not overload the bearings with a shim that is too thick as damage may occur.

NOTE: Select a shim with a thickness equal to the Dial Indicator Gauge reading. This will provide zero end play. Install the thickest shim closest to the front bearing cup to provide support for the cup.

Rotate the transmission to the horizontal position and remove the input shaft bearing retainer. Remove the bearing race and install the necessary shim(s).

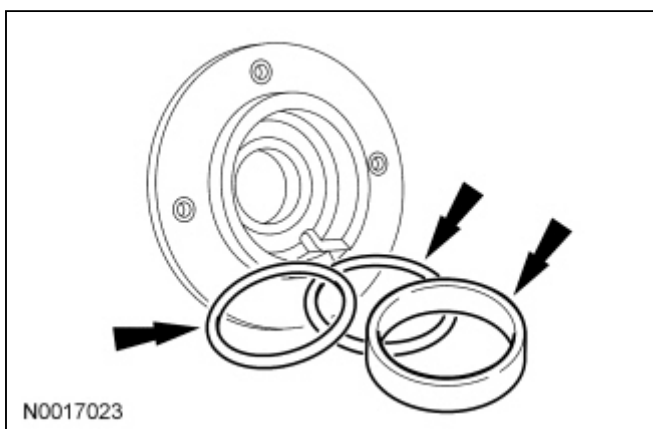

45. Apply a 3.2 mm (0.125 in) bead of silicone rubber to the sealing surface on the input shaft bearing retainer. Do not cover the notch in the input shaft bearing retainer with sealer.
46. Install the input shaft bearing retainer and the 4 bolts.
 - Tighten to 21 Nm (15 lb-ft).

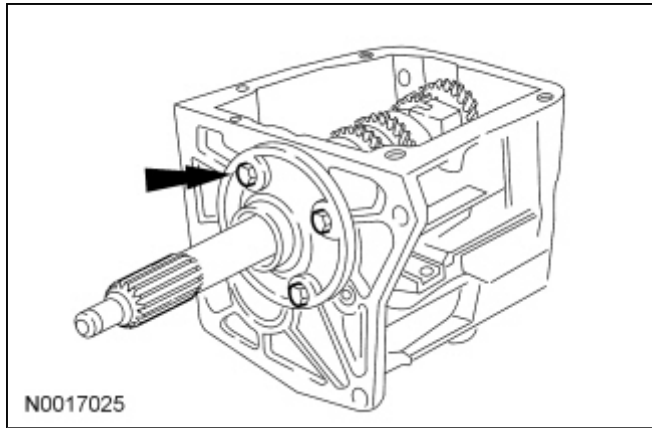

47. Apply a 3.2 mm (0.125 in) bead of silicone rubber to the sealing surface on the gearshift lever.
48. Install the shift cover plate and the 4 shift cover plate bolts.
 - Tighten to 19 Nm (168 lb-in).

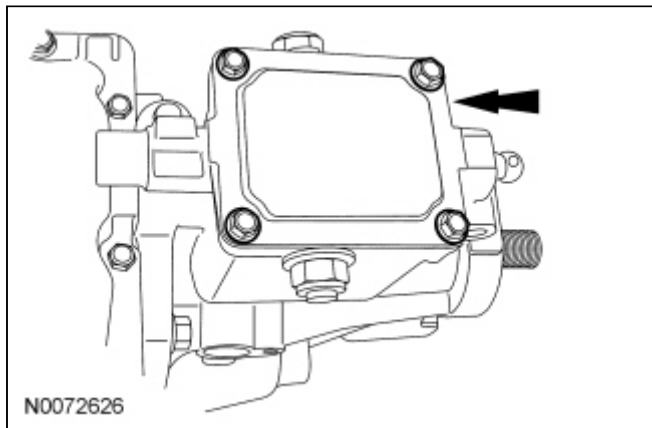

49. **NOTE:** Apply thread sealant to the drain plug threads.

Install the drain plug.

- Tighten to 18 Nm (159 lb-in).

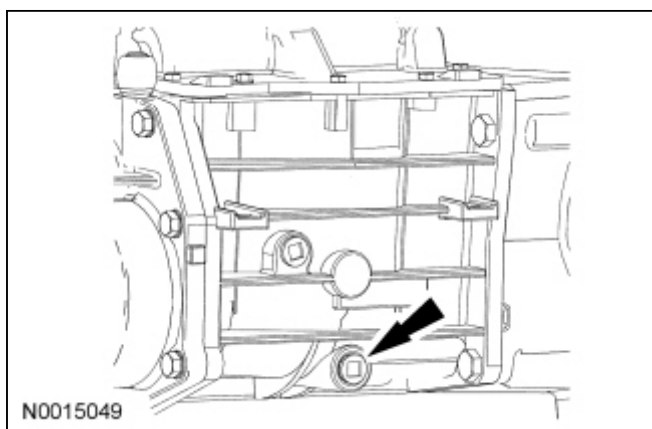

50. Install the Output Shaft Speed (OSS) sensor.
 - Tighten to 10 Nm (89 lb-in).

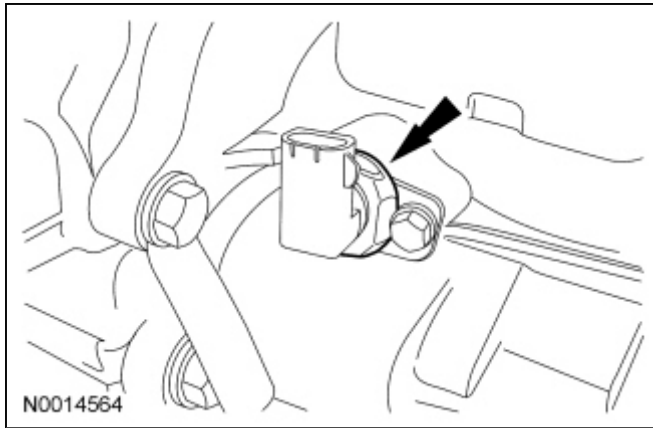

51. Position the output flange onto the output shaft. Install the thrust washer and output flange nut. Tighten until the output flange is fully seated.
52. Remove the output flange nut and thrust washer.
53. Install a new flange seal. Carefully push it through until it is fully seated against the flange and output flange pocket.
54. Install the thrust washer and output flange nut.
 - Tighten to 142 Nm (105 lb-ft).
55. Install the clutch housing to the transmission.
 - Tighten to 31 Nm (23 lb-ft).

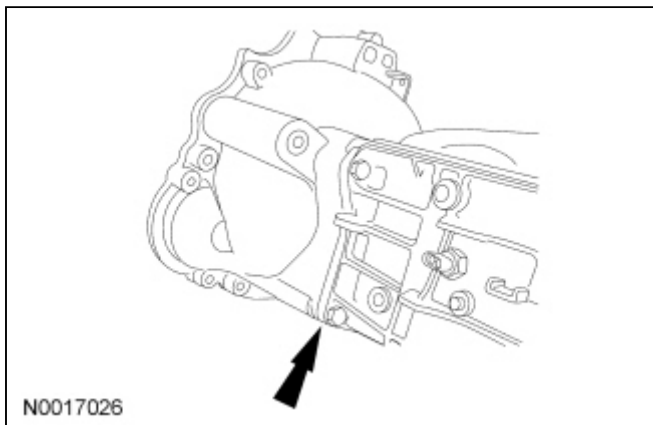

56. Install a new clutch slave cylinder retaining clip.
57. Install the clutch slave cylinder.
 - Tighten to 20 Nm (177 lb-in).

